



Y. LIN ELECTRONICS CO., LTD.

Data Sheet

Customer: _____
Part No: _____ YLS150/RV/21/11-H _____
Sample No: _____ 7L20170506-111YF _____
Description: _____ S150 Red/Yellow-Green SMD _____
Item No: _____ 4532454 _____

Customer			
Check	Inspection	Approval	Date

Y.LIN			
Drawn	Check	Approval	Date
			201705-26

Mainland address: Jinhe The Third Industrial Zone, Zhangmutou Town, Dongguan, Guangdong, China

Mainland address: Jinhe The Third Industrial Zone, Zhangmutou Town, Dongguan, Guangdong, China

TEL: 0769-87181888 FAX: 0769-87187333 E-mail: yonglin@y-lin.com Http://www.yong-lin.net



Features:

- . Wide Viewing Angle 120°
- . Reflow Solderable
- . High Luminous Intensity and Low Power Dissipation
- . Good Reliability and Long Life
- . Complied With RoHS Directive

Technical Data Sheet

This product is generally used as indicator and luminary for electronic equipment such as household appliance, communication equipment, and dashboard.

Applications

- Optical indicator
- Indoor display
- Backlighting in dashboard and switch
- Flat backlighting for LCD, symbol and display
- General use

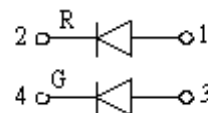
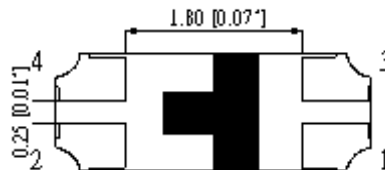
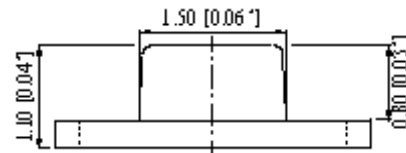
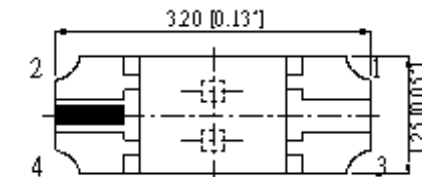
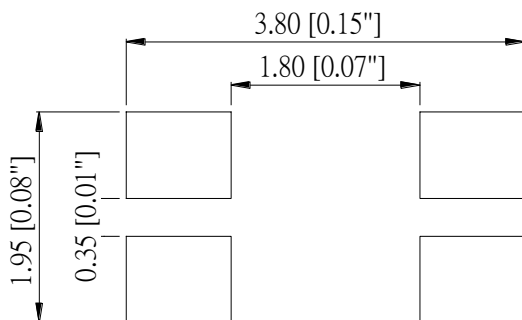

Notes:

1. All dimension units are millimeters.
2. All dimension tolerance is $\pm 0.2\text{mm}$ unless otherwise noted.



YLS150/RV/21/11-H

Selection Guide

Part No.	Dice	Lens Type	Luminous intensity(mcd) @ 30mA			Viewing Angle
			Min	Typ	Max	2θ1/2
YLS150/RV/21/11-H	(R)AlGaInP	Water transparent	100	--	170	130
	(V)InGaN		50	--	100	

Note:

- 1.2θ1/2 is the angle from optical centerline where the luminous intensity is 2θ1/2 the optical centerline value.
- 2.The above luminous intensity measurement allowance tolerance ±10%

Electrical / Optical Characteristics at Ta=25 °C

Parameter	Symbol	Min.(R/V)	Typ.(R/V)	Max(R/V)	Units	test conditions
Forward Voltage	VF	1.8/1.8	2.1/2.1	2.4/2.4	V	IF=30mA
Reverse Current	IR	--	--	10	uA	VR = 5V
Dominate Wavelength	λd	620/565	--	630/575	nm	IF=30mA

Absolute Maximum Ratings at Ta=25 °C

Parameter	Symbol	Rating	Units
Power Dissipation	Pd(R/V)	90/90	mW
DC Forward Current	IF	30	mA
Peak Forward Current [1]	IFP	50	mA
Reverse Voltage	VR	5	V
Electrostatic Discharge (HBM)	ESD	2000/4000/4000	V
Operating Temperature	Topr	-30~+85	°C
Storage Temperature	Tstg	-40~+100	°C

Note:

1. 1/10 Dut cycle,0.1ms pulse width.
2. The above forward voltage measure ment allowance tolerance ±0.1V.



Typical optical characteristics curves

Ambient Temperature VS. Forward Current

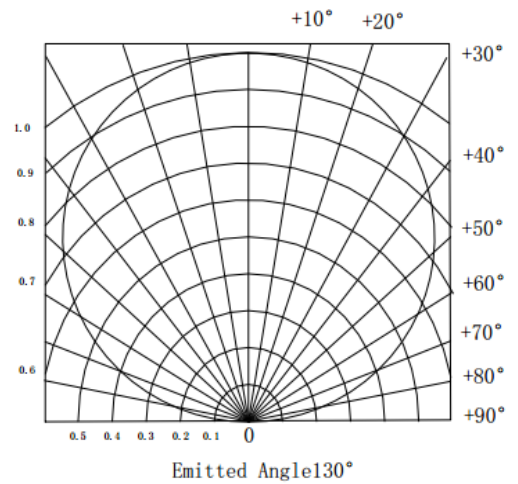
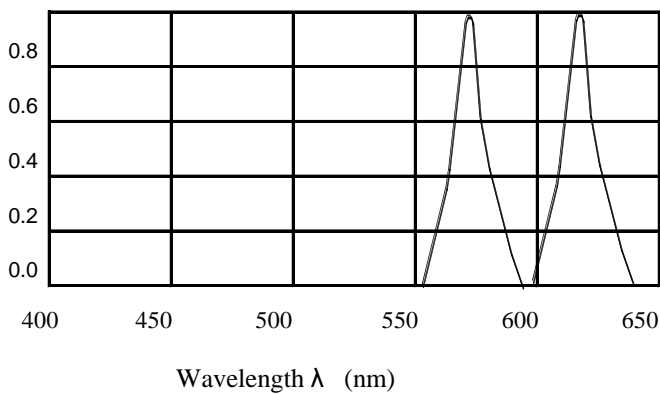
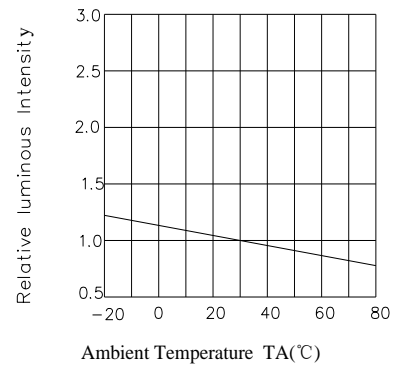
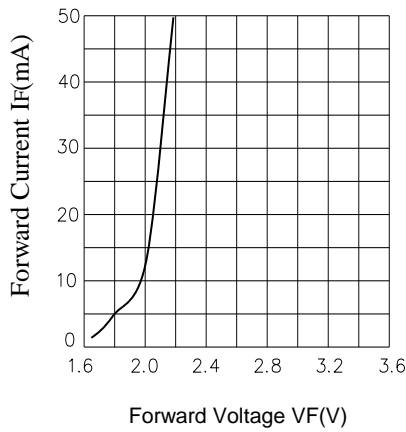
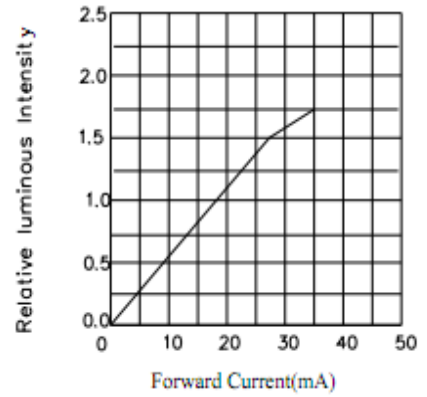
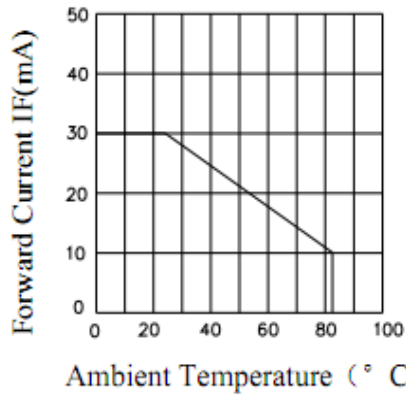



Reliability Test Items And Conditions

The reliability of products shall be satisfied with items listed below.

Confidence level :90%

LTPD :10%

Test Items	Test conditions	Quantity	Judging Criteria
Solderability	Solder Temperature: 240°C Solder Duration: (3.5±0.5) sec.	22	Solderable Area Over 95%
Thermal Shock Followed by High Temperature And High Humidity Cyclic	-40°→10min 5 Cycles ↑ ↓ shift(2~3)min 100°C →10 min. 25°C~55°C (90%~95%) RH 2 Cycles for 48 hrs., Recover for 2 hrs	22	C=0 & I**
Resistance For Soldering Heat	Reflow Soldering	22	C=0 & I**
DC Operating Life	1000 hrs. Forward Current: 30mA	22	C=0 & I**
High Temperature Storage	100°C → 1000 hrs	22	C=0 & I**
High Temperature And High Humidity Cyclic	25°C~55°C (90%~95%) RH 6 Cycles for 144 hrs., Recover for 2 hrs.	22	C=0 & I**

The technical information shown in the data sheets are limited to the typical characteristics and circuit examples of the referenced products. It does not constitute the warranting of industrial property nor the granting of any license.



SMT Reflow Soldering Instructions

1. Reflow soldering is not can do two times
2. When soldering , do not put stress on the LEDs during heating .

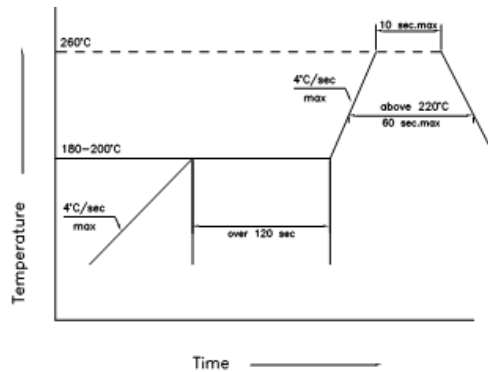

3. Product is highest resistant to 260°C , reflow but suggested the highest temperature of 240°C within .

Soldering iron

1. When hand soldering, the temperature of the iron must less than 300°C for 3 seconds
2. The hand solder should be done only one times

Repairing

Repair should not be done after the LEDs have been soldered. When repairing is unavoidable, a double-head soldering iron should be used (as below figure). It should be confirmed beforehand whether the characteristics of LEDs will or will not be damaged by repairing.

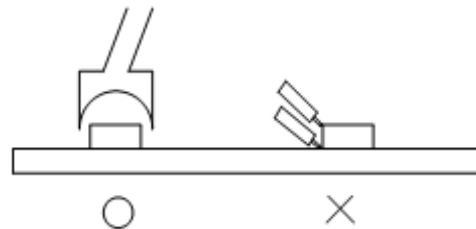

Cautions

The encapsulated material of the LEDs is silicone. Therefore the LEDs have a soft surface on the top of package. The pressure to the top surface will be influence to the reliability of the LEDs. Precautions should be taken to avoid the strong pressure on the encapsulated part. So when use the picking up nozzle, the pressure on the silicone resin should be proper.

Handling Precautions

1. Do not stack together assembled PCBs containing LEDs. Impact may scratch the silicone lens or damage.
2. Not available in the situation of acidity for PH.

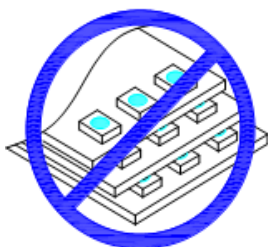



YLS150/RV/21/11-H

Package:

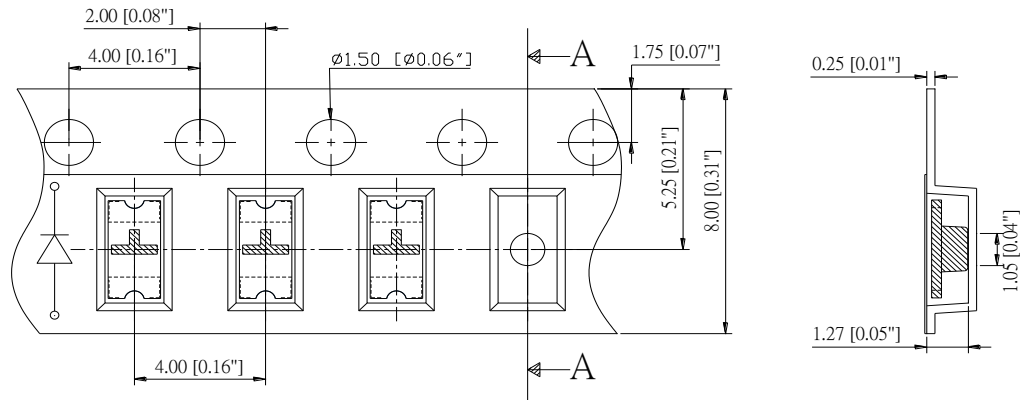

All dimensions in mm, tolerances unless mentioned is ± 0.1 mm.

