



Y. LIN ELECTRONICS CO., LTD.

Data Sheet

Customer: _____
Part No: YLS150/V/21/08-T
Sample No: YL20180208-7124Y
Description: 1206 Yellow-Green SMD
Item No: _____

| Customer | | | |
|----------|------------|----------|------|
| Check | Inspection | Approval | Date |
| | | | |

| Y.LIN | | | |
|-------|-------|----------|----------|
| Drawn | Check | Approval | Date |
| | | | 2017/5/3 |

TEL:0769-87181888

FAX:0769-87187333

E-mail:yonglin@y-lin.com [Http://www.yong-lin.net](http://www.yong-lin.net)

Mainland address:Jinhe the third Industrial Zone,Zhangmutou Town

Dongguan Guangdong China

H.K address:Unit 503 5/F,Silvercord Tower 230 Canton Road Tsimshatsui



Features:

- . Reflow Solderable
- . High Luminous Intensity and Low Power Dissipation
- . Good Reliability and Long Life
- . Complied With RoHS Directive

Technical Data Sheet

This product is generally used as indicator and luminary for electronic equipment such as household appliance, communication equipment, and dashboard.

Applications

- Optical indicator
- Indoor display
- Backlighting in dashboard and switch
- Flat backlighting for LCD, symbol and display
- General use

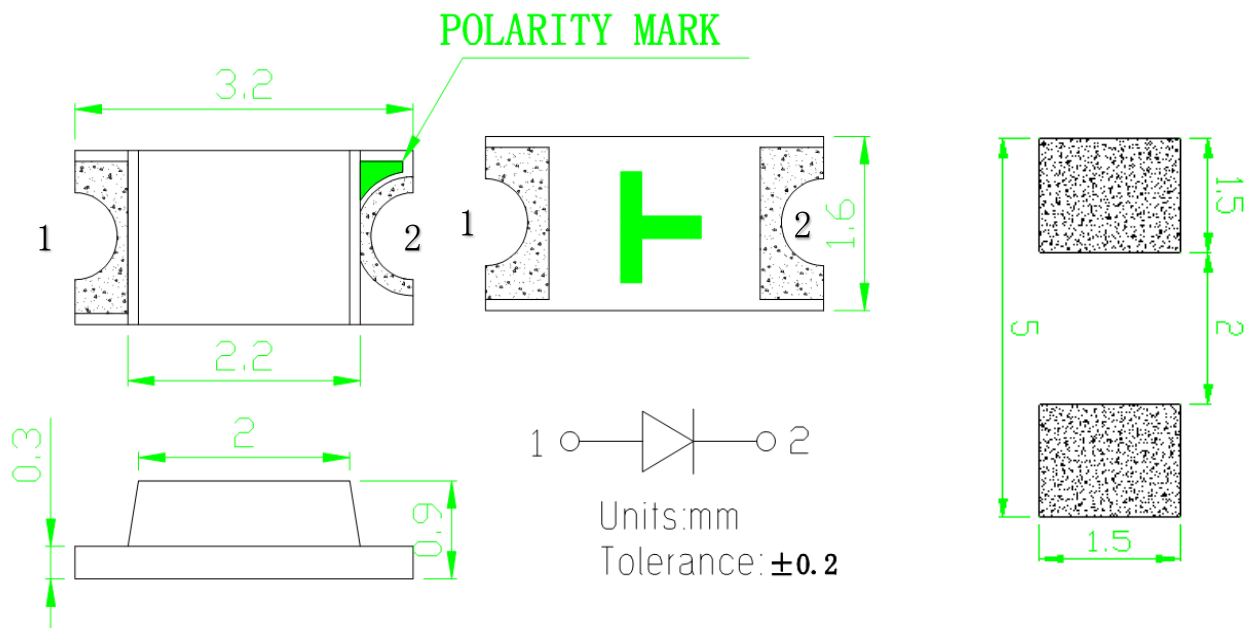

Notes:

1. All dimension units are millimeters.
2. All dimension tolerance is ± 0.2 mm unless otherwise noted.



YLS150/V/21/08-T

Selection Guide

| Part No. | Dice | Lens Type | Luminous intensity(mcd) @ 20mA | | | Viewing Angle |
|------------------|------------------------|-------------|--------------------------------|-----|-----|---------------|
| | | | Min | Typ | Max | 2θ1/2 |
| YLS150/V/21/08-T | Yellow-Green (AlGaInP) | Water Clear | 20 | -- | 50 | 120 |

Note:

1.2θ1/2 is the angle from optical centerline where the luminous intensity is 2θ1/2 the optical centerline value.

2.the above luminous intensity measurement allowance tolerance ±10%

Electrical / Optical Characteristics at Ta=25 °C

| Parameter | Symbol | Min. | Typ. | Max | Units | test conditions |
|---------------------|--------|------|------|-----|-------|-----------------|
| Forward Voltage | VF | 1.8 | -- | 2.4 | V | IF=20mA |
| Reverse Current | IR | -- | -- | 10 | uA | VR = 5V |
| Dominate Wavelength | λd | 560 | -- | 575 | nm | IF=20mA |

Absolute Maximum Ratings at Ta=25 °C

| Parameter | Symbol | Rating | Units |
|-------------------------------|--------|----------|-------|
| Power Dissipation | Pd | 60 | mW |
| DC Forward Current | IF | 20 | mA |
| Peak Forward Current [1] | IFP | 40 | mA |
| Reverse Voltage | VR | 5 | V |
| Electrostatic Discharge (HBM) | ESD | 2000 | V |
| Operating Temperature | Topr | -40~+85 | °C |
| Storage Temperature | Tstg | -40~+100 | °C |

Note:

- 1/10 Dut cycle,0.1ms pulse width.
2. The above forward voltage measurement allowance tolerance ±0.1V.
3. The tolerance of wave length: ±1nm.



Typical optical characteristics curves

Ambient Temperature VS. Forward Current

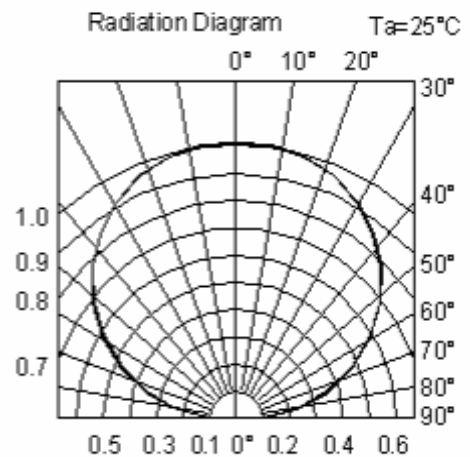
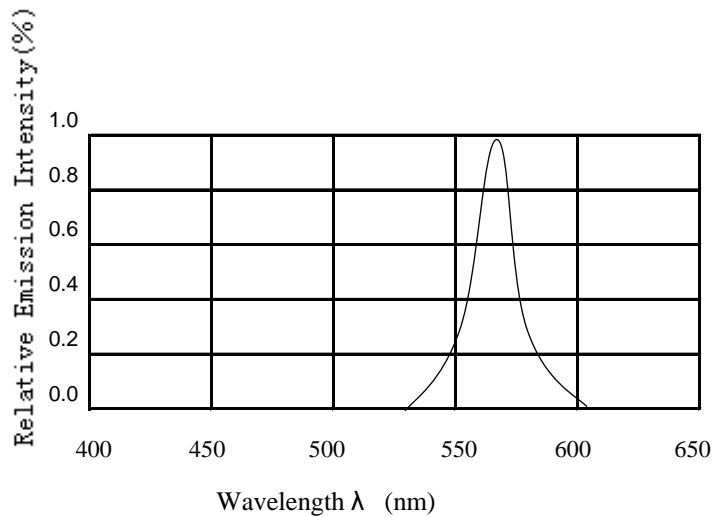
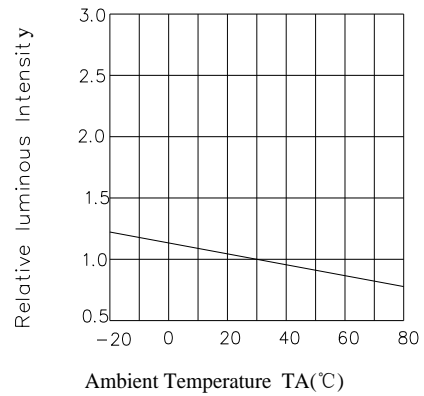
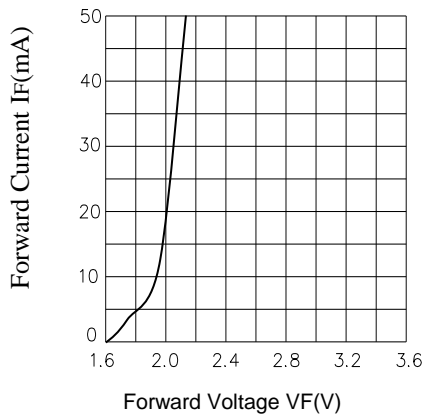
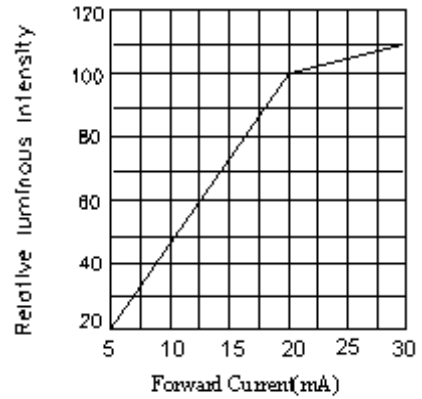
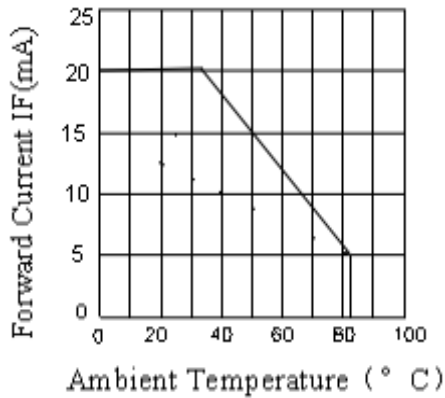



Reliability Test Items And Conditions

The reliability of products shall be satisfied with items listed below.

Confidence level :90%

LTPD :10%

| Test Items | Test conditions | Quantity | Judging Criteria |
|---|---|----------|-----------------------------|
| Solderability | Solder Temperature: 240°C Solder Duration: (3.5±0.5) sec. | 22 | Solderable Area Over 95% |
| Thermal Shock Followed by High Temperature And High Humidity Cyclic | -40°→10min 5 Cycles ↑ ↓ shift(2~3)min 100°C →10 min. 25°C~55°C (90%~95%) RH 2 Cycles for 48 hrs., Recover for 2 hrs | 22 | C=0 & I** |
| Resistance For Soldering Heat | Reflow Soldering | 22 | C=0 & I** |
| DC Operating Life | 1000 hrs. Forward Current: 20mA | 22 | C=0 & I** |
| High Temperature Storage | 100°C → 1000 hrs | 22 | C=0 & I** |
| High Temperature And High Humidity Cyclic | 25°C~55°C (90%~95%) RH 6 Cycles for 144 hrs., Recover for 2 hrs. | 22 | C=0 & I** |

The technical information shown in the data sheets are limited to the typical characteristics and circuit examples of the referenced products. It does not constitute the warranting of industrial property nor the granting of any license.



YLS150/V/21/08-T

SMT Reflow Soldering Instructions

- 1.Reflow soldering should not exceed once.
- 2.In soldering process , do not stress on the LEDs during heating .

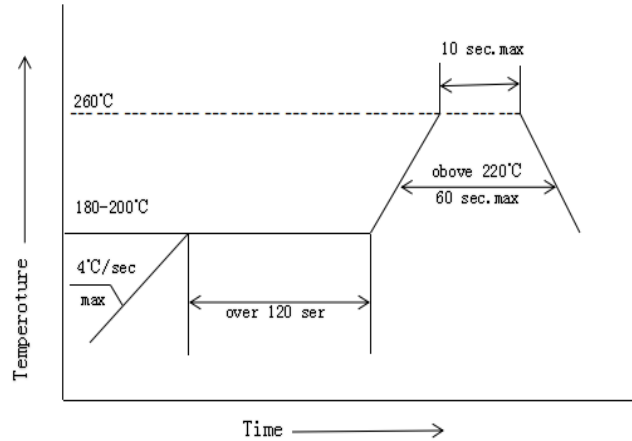

Soldering iron

- 1.When hand soldering, the temperature of the iron must lower than 300°C for 3 seconds
- 2.The hand solder should be done only one time

Repairing

Repair should not be done after the LEDs have been soldered. When repairing is unavoidable, a double-head soldering iron should be used (as below figure). It should be confirmed beforehand whether the characteristics of LEDs will or will not be damaged by repairing.

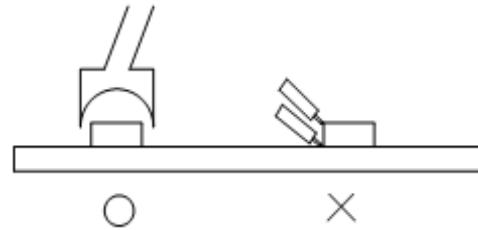

Storage

The package is sealed:

- 1.Recommended storage condition :At 5°C~30°C and relative humidity 90% RH max.
- 2.It is recommended that SMD out of their original packaging are used within one year.

The package is opened:

- 1.After this bag is opened ,devices that will be applied to infrared to infrared reflow,vapor-phase reflow.
 - a.Completed within 672 hour.
 - b.Stored at 5°C~30°C and 60% RH or less.
- 2.If baking is required,devices must be baked under below conditions 24 hours at 60°C±3°C

Handling Precautions

- 1.Do not stack together assembled PCBs containing LEDs. Impact may scratch the silicone lens or damage.

- 2.Not available in the situation of acidity for PH.

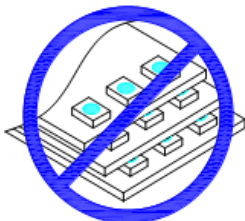



Y. LIN ELECTRONICS CO., LTD.

YLS150/V/21/08-T

Packaging

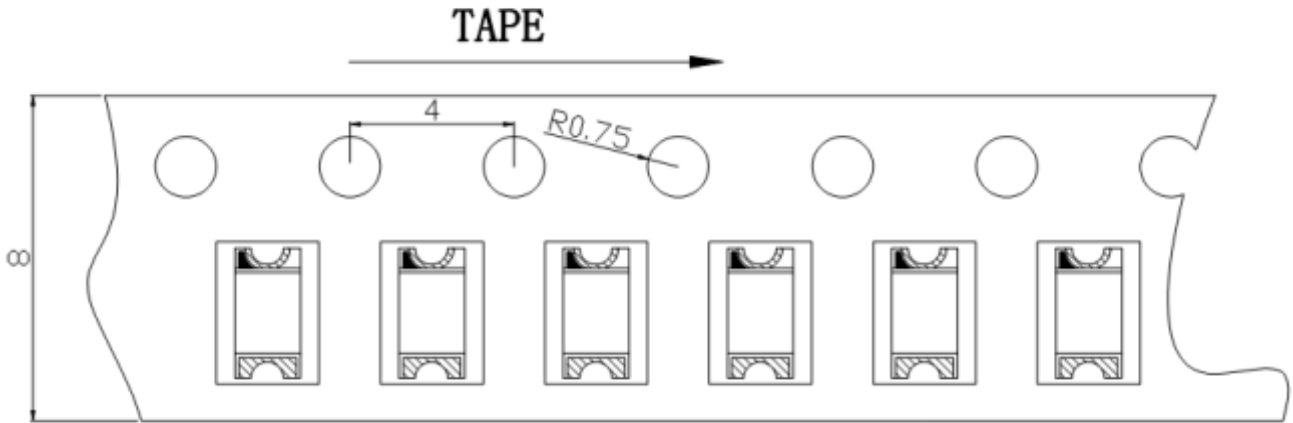

Package: 3000 pcs/reel

Reel Dimensions

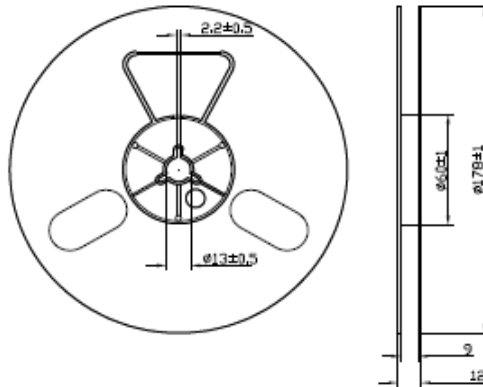

Note: The tolerances unless mentioned is ± 0.1 mm, Unit: mm

Moisture Resistant Packaging

